



Vacuum Jacketed Pipe Technical Manual



Midwest Cryogenics
100 2nd Street NE
PO Box 47
Montgomery MN 56069
Phone: 507-364-8633
Fax: 507-364-8637
www.midwestcryo.com

Table of Contents

Preface	1
Midwest Cryogenics	1
Introduction	2
Vacuum Jacketed Pipe	2
Sizing Guide	2
System Design Checklist	3
Rigid Vacuum Jacketed Pipe Analysis	3
Typical Attributes for Vacuum Jacketed Pipe	4
Cost Savings Calculations for VJP versus Foam Insulated Pipe	4
Installation	5
Bayonet Connections	5
Bayonet Installation Guide	5
Field Joint Couplings	6
Equipment Needed	6
Field Joint Installation Guide	6
Specifications and Disclaimer	8
Cryogenic Liquid Piping System	8
Cryogenic Materials	8
Related Codes and Standards	8
Vacuum Jacketed Piping (VJP) System	8
Warranty	9
Accessories	10

Preface

Midwest Cryogenics

Midwest Cryogenics handles all of your cryogenic needs. Our process from beginning to end is thorough, delivering a high level of service and commitment. Whether you need help determining the most efficient system for your application, installation of your cryogenic equipment, or on-site repairs, you can trust Midwest Cryogenics to get the job done right.

Midwest Cryogenics provides a wide range of new and used products for storage, distribution, and end user applications. From design, to installation and start-up, you can trust Midwest Cryogenics to deliver a reliable, cost effective system. We offer:

- New and Used Tank Sales
- Vaporizers
- Vacuum Insulated Pipe and Accessories
- Cryogenic Valves
- Test Chambers



Midwest Cryogenics Vacuum Jacketed Pipe Manual

Introduction

Midwest Cryogenics provides stainless steel super-insulated Vacuum Jacketed Piping (VJP) systems used for the transfer of liquid nitrogen, oxygen, argon, carbon dioxide, and helium. Each VJP system is custom designed to meet the requirements of the application, while keeping the system economics within budget.

Vacuum Jacketed Pipe

Midwest Cryogenics uses stainless steel pipe in the manufacturing of its Vacuum Jacketed Pipe. VJP contains an inner line for the transfer of cryogenic liquids with an outer vacuum jacket. The vacuum annular space consists of a multi-layered insulation with an extremely low vacuum level of 9 microns or less. VJP is fifty times more effective than conventional foam-insulated copper in preventing heat leak to the inner line, and VJP is extremely long lasting. Midwest Cryogenics builds the VJP to ASME B31.3 Code for Process Piping.

Midwest Cryogenics prefers the use of inner line expansion joints. With the use of stainless steel inner expansion joints, the pipe supports for our VJP need not compensate for the thermal expansion of the inner line (3.86 in/100 ft for LN₂).

For lengths of jacketed pipe over forty feet in length, it is necessary to divide the pipe into individual spool sections. We offer two options: either a bayonet joint, or a field joint coupling. A bayonet is a mechanical joint used for lines that can be dismantled and reassembled easily while maintaining a low heat in-leak at the joint. These close-tolerance bayonets consist of a male bayonet that couples with the female bayonet so that no liquid will flow past the seal because the silicon O-ring completes the seal. The flanges are held in place by a quick release V-band clamp. The other type of connection, field joint coupling is vacuum insulated. This joint begins with a welded coupling between the spools that is then wrapped with our super-insulation and then evacuated to our standard vacuum level. The assembly consists of an outer sleeve that is field welded to collars that are attached to the VJP spools on either side.

Sizing Guide

Midwest Cryogenics provides VJP with inner pipe sizes ranging from ½" to 8" and larger for rigid pipe, and ½" to 6" for flexible pipe.

When determining the configuration for your piping layout, remember the constraints imposed by shipping (7½" x 7½" x 40') and installation; one must consider these factors when designing spool lengths for fabrication.

System Design Checklist

- Determine basic routing of the nitrogen system, such as bulk tank location, equipment location, and piping elevation.
- Provide an isometric sketch to clarify piping configuration. We will then provide isometric drawings with dimensions for your verification.
- Size the pipe and components based on current flow rates while providing for future expansion.
- Identify liquid demands to help Midwest Cryogenics determine the components needed to maximize your piping system's efficiency.
- Highlight any installation points of interest such as wall penetrations, close quarters, existing fixtures, dropped ceilings, etc.
- Determine any installation restrictions for length with regards to access for pipe and assembly.
- Midwest Cryogenics can provide turnkey packages to avoid customer drawing or flow calculation errors.

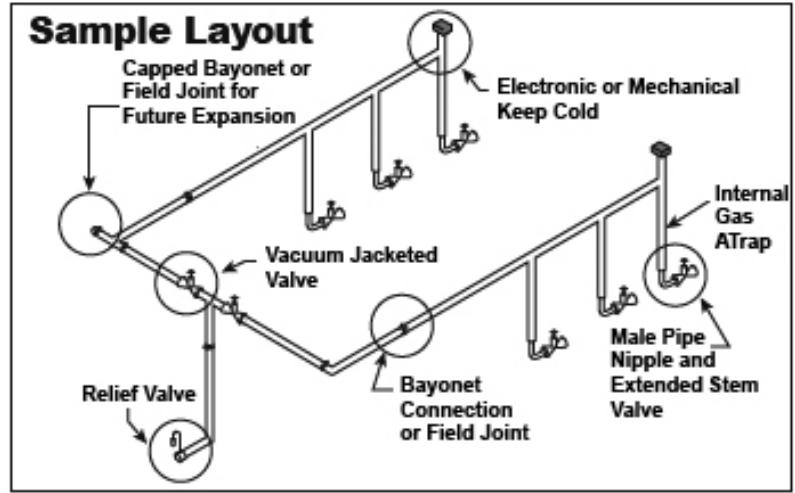

Rigid Vacuum Jacketed Pipe Analysis

Inner Pipe Size Material	Jacket Pipe Size Material	Total Weight	Cooldown lb of LN2/ft Kg of LN2/m	Heat Leak BTU/Hr/Ft (Watt/m)	Bayonet Heat BTU/Hr (Watt)	Field Joint BTU/Hr (Watt)
½" SCH 5 21.3 mm OD 304SS	2" SCH 5 60.3 mm OD 304SS	2.4 lb/ft 3.6 kg/m	0.27 (0.40)	0.32 (0.31)	6.6 (1.9)	5.9 (1.7)
1" SCH 5 33.4 mm OD 304SS	3" SCH 5 88.9 mm OD 304SS	4.2 lb/ft 6.2 kg/m	0.43 (0.64)	0.45 (0.43)	9.1 (2.7)	5.9 (1.7)
1½" SCH 5 48.3 mm OD 304SS	3½" SCH 5 101.6 mm OD 304SS	5.0 lb/ft 7.4 kg/m	0.64 (0.95)	0.56 (0.54)	13.3 (3.9)	8.5 (2.5)
2" SCH 5 60.3 mm OD 304SS	4" SCH 5 114 mm OD 304SS	5.8 lb/ft 8.6 kg/m	0.80 (1.19)	0.75 (0.72)	20.9 (6.1)	11.5 (3.4)
3" SCH 5 88.9 mm OD 304SS	5" SCH 5 141 mm OD 304SS	9.8 lb/ft 14.6 kg/m	1.51 (2.25)	0.98 (0.94)	28.1 (8.2)	29.4 (8.6)
4" SCH 5 114 mm OD 304SS	6" SCH 5 168 mm OD 304SS	12.0 lb/ft 17.9 kg/m	1.96 (2.92)	1.28 (1.23)	66.1 (19.4)	35.3 (10.3)

Typical Attributes for Vacuum Jacketed Pipe

- Bayonet couplings for ease of installation.
- Field welded couplings for lower heat in-leak and material costs.
- 1" to 2" headers for main or high usage branch runs, or larger where necessary.
- ½" drops to equipment.
- Vacuum jacketed in-line valves for branch isolation during shut-down or repair.
- DV-6R for monitoring vacuum level of VJP as an option.
- Internal gas traps that prevent frosting of standing end connections when not in use.
- System relief valve for line safety (if located indoors, this should be piped to the exterior).
- Electronic or Mechanical Keep-Colds maintain cold temperatures at the main header and use points.
- Capped bayonet or field joint coupling for future expansion.
- Extended stem cryogenic control valves (usually end-use conditions).
- VJP for use with vibrating equipment or minimizing alignment problems.

Cost Savings Calculations for VJP versus Foam Insulated Pipe

The following example is based on a service of liquid nitrogen running through 200 feet of 1" x 3" of Midwest Cryogenics' VJP with bayonet joint versus foam insulated 1" pipe. Operating parameters of 24 hours/day and 365 days/year are used to indicate a system with a Keep-Cold unit installed.

	<u>Input Values</u>
Heat loss for VJP (BTU/ft x hr)	0.45
Heat loss for foam insulated pipe (BTU/ft x hr)	20
Overall length of pipe (ft)	200
Heat loss for joints in VJP (BTU/hr)	9.1
Number of joints in VJP	7
Daily usage (hrs/day)	24
Days per year	365
Heat of vaporization of cryogenic liquid (BTU/lb)	85.6
Cost of cryogenic liquid (\$/lb)	0.04
	 <u>Cost Due to Heat Leak</u>
\$ per year for VJP	\$629.16
\$ per year for foam insulated pipe	\$16,373.83
\$ per year savings using VJP instead of foam insulated pipe	\$15,744.67

Formulas:

Heat loss/hr=(heat loss/hr/ft of pipe x pipe length) + (heat loss/joint/hr x number of joints)

\$/year=(heat loss/hour x hours/day x days/year)/heat vaporization

Notes:

1. The cost per pound of liquid nitrogen may vary considerable based on market changes. Consult your gas supplier for current costs. For this example, the following price was used (\$0.04/lb=\$0.29/100SCF).
2. These calculations do not included cooled down losses.
3. These calculations are used to demonstrate the relative efficiency of VJP versus foamed copper piping, not to predict actual system losses. Actual system losses include a number of variables represented by these calculations.

Please contact Midwest Cryogenics for custom calculations of your system.

Installation

Bayonet Connections

A bayonet is a mechanical connection between two sections of VJP that eliminates the need for any welded connections. The bayonet is a low heat in-leak device with telescoping male and female components. Due to a close tolerance design, our “low-profile” bayonets utilize a metal-to-metal in-line seal with a silicone O-ring placed between the flanges. This combines to make a reliable, heavy-duty cryogenic seal between the two VJP sections, and simultaneously preserves the low-heat in-leak of the system.



Bayonet Installation Guide

1. Place pipe supports every 10 feet (3m). Distance may vary by sizing and change of direction.
2. Place pipe on supports before engaging bayonets, when possible.
3. Check alignment and slope of piping. The slope should be up in the direction of keepfull and 1" (25mm) up for every 50 feet (15.2m) in length.
4. Inspect the male bayonet nose end. It must be clean and free of burrs or damage.
5. Wipe bayonet couplings and O-ring with a lint-free cloth.
6. Lightly coat the silicone O-ring with a thin film of the supplied lubricant, and slide the ring over the nose of the male bayonet and place it in the groove.
7. Coat the machined nose of the male bayonet with a thin film of the supplied lubricant to prevent galling during installation. Place V-Band between the bayonets.
8. Engage the male and female bayonets (do not twist) and tighten the V-band to a loose fit. If resistance is felt, re-check alignment and re-engage.
9. Continue installing adjacent sections until all are engaged and in place.
10. Fine tune support heights to provide a smooth sloping pipe back to the tank.
11. When all is in place, tighten V-bands to a snug fit.
12. Finally, visually inspect the entire system, looking for stress risers and sufficient pipe supports.

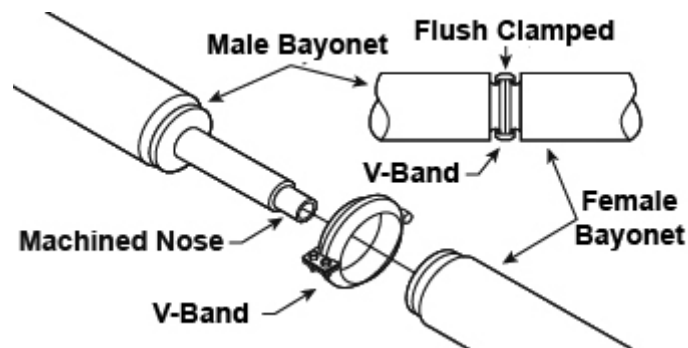

Note: Bayonets that are cold (that have been in service) must be warmed to close to room temperature before disengaging. To do this, the VJP must be drained of liquid and allowed to warm up for approximately 24 hours before attempting disengagement. Contact Midwest Cryogenics if a more rapid time is necessary.

Field Joint Couplings

Field joint couplings are vacuum-insulated, field-welded connections between two sections of VJP. Field joint couplings have a long heat-leak transition between the outer jacket and the inner pipeline to reduce the heat input into the system. After the weld is made, the joint is insulated and a coupling is moved into place over the section. The coupling is then field welded to the collars on the ends of the two piping spools. This coupling is then evacuated to a new low vacuum to ensure a low heat-leak. This type of system is usually installed by Midwest

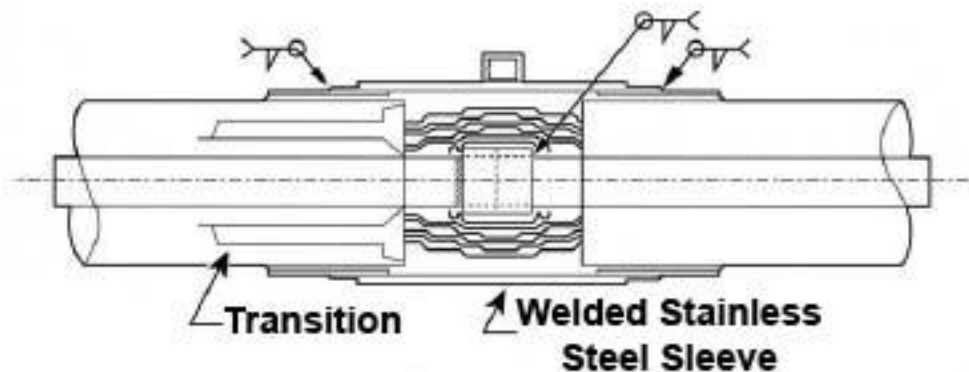

Cryogenics.

Equipment Needed

1. GTAW welding equipment and an ASME qualified welder (with qualified procedure) to make a Fillet Weld on SA-312 Type 304 Stainless Steel pipe.
2. Field Joint Insulation Kit (supplied with VJP section by Midwest Cryogenics)
 - a. Multi-layered insulation (paper and foil pre-wrap)
 - b. Molecular sieve packages
 - c. PDO
3. Field Joint Assembly Kit (supplied with VJP section by Midwest Cryogenics)
 - a. Field joints coupling with pump-out port
 - b. Socket weld coupling
4. Vacuum Pump
5. Evacuation Fixture
6. Aluminum tape or copper wire

Field Joint Installation Guide

1. Before welding the VJP sections together, slide the outer coupling over the end of one section.
2. Move the two sections together before engaging the inner line weld socket.
3. Weld at the weld socket with an approved ASME procedure.
4. Appropriately inspect the weld to ensure a leak-proof seal.
5. Slide the next VJP section into place and repeat steps 1-4.

6. Once complete, if pressure testing is specified, do that testing now.
7. Clean and dry the joint areas. All parts exposed to vacuum must be clean and free of any oils or solvents and must be dry.
8. Insulate the field joints in the following manner:
 - a. Attach the sieve packages to the inner pipe (copper wire or aluminum tape). The proper amount of sieve is provided with each kit for each pipe size.
 - b. Puncture each package with a number of small holes (approximately 20).
 - c. Wrap the insulation pre-wrap over the inner line. The insulation should be wrapped around the inner line, overlapping itself half-way.
 - d. Secure the insulation loosely with copper wire or aluminum tape.
 - e. Secure the hydrogen getter packet to the outside of the insulation with copper wire.
9. Attach the field joint coupling:
 - a. Slide the coupling over the insulation so that it is centered over the non-insulated area.
 - b. Weld the coupling to the collars attached to the outer jacket on each side of the joint using an approved ASME procedure.
 - c. Attach the vacuum pump operator to the pump-out port and then evacuate the field joint coupling below 15 microns.

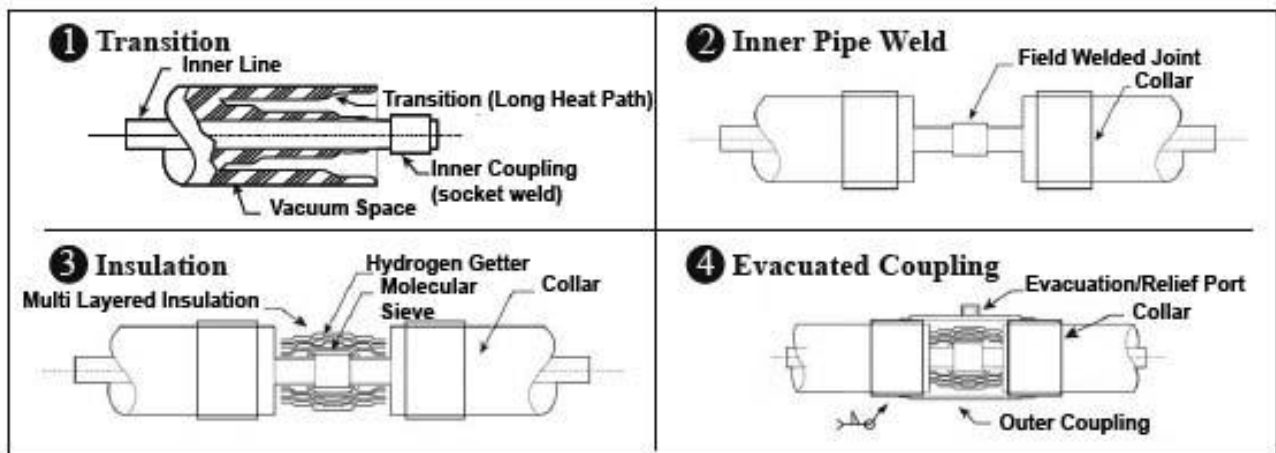

Questions? Contact Midwest Cryogenics at:

100 2nd Street NE
 PO Box 47
 Montgomery MN 56069
 Phone: 507-364-8633
 Fax: 507-364-8673
www.midwestcryo.com

Specifications and Disclaimer

Cryogenic Liquid Piping System

Cryogenic Materials

The equipment that is provided is manufactured for use with extremely low temperatures -320°F (-196°C). Any material coming into contact with liquid nitrogen must be stainless steel, brass, bronze, copper, aluminum, Teflon™ or Kel-F. Any material coming in contact only with cold vapors must be appropriate for extremely low temperatures.

Related Codes and Standards

The equipment that is provided under this specification should be manufactured to the appropriate codes and specifications, including but not limited to the following:

1. Bulk Storage Tanks
 - ASME Section 8, Division 1—unfired pressure vessel. The liquid storage vessel must comply with the latest addendum.
2. Vacuum Jacketed Pipe
 - ANSI Section B31.3 Process Piping

Vacuum Jacketed Piping (VJP) System

The Vacuum Jacketed Piping (VJP) system is designed for the efficient transfer of liquid nitrogen at pressures up to standard 150 psi (10.34 bar) or greater. The normal operating pressure and the flow requirements are determined by the liquid nitrogen storage tank, and the equipment requirements. Midwest Cryogenics is available for consultation on the appropriate sizing of the VJP system.

The VJP system is made up of individual components. These components include VJP sections, cryogenic valves, fittings, and Electronic or Mechanical Keep-cold assemblies.

Midwest Cryogenics VJP is a double-walled construction that has an inner pipe for the transfer of liquid nitrogen, and an outer pipe to support and retain the vacuum insulation. The inner and outer pipe is constructed with type 304 stainless steel.

The insulation is a low vacuum with multiple layers of paper and foil (super insulation) applied in such a way as to reflect back radiant heat. Molecular sieves and getters are used with the insulation system to maintain low vacuum levels for many years.

Thermal contraction of Midwest Cryogenics' VJP system is accommodated by the inner pipe, so the outer jacket of the VJP system does not require special roller hangers.

The VJP sections are designed and built with a factory sealed vacuum and super insulation system. The sections may be connected together with either a mechanical bayonet coupling, or a welded field-joint coupling.

An optional thermocouple vacuum gage and bellow seal isolation valve is used to determine the vacuum level of each section in the field.

The VJP system meets the required codes and specifications for cryogenic piping, specifically ASME B31.3.

Warranty

Midwest Cryogenics warrants to the purchaser of the Vacuum Jacketed Pipe that the product shall be free from defects in material and workmanship that result in breakdown or failure under normal use for a period of two (2) years from the date of shipment to the original purchaser. Midwest Cryogenics also warrants all component plumbing parts for two (2) years or the manufacturer's warranty if the equipment is used and maintained in a proper manner. Any warranty contained herein shall not apply to any Vacuum Jacketed Pipe that has been repaired or altered outside the manufacturer's facilities or in any way so as to affect the stability or reliability of the Vacuum Jacketed Pipe; or any Vacuum Jacketed Pipe that has been subject to misuse, negligence, or accidental damage.

The manufacturer's liability under this warranty shall be limited to the lesser of the repair, replacement, or refund of the purchase price paid by the original purchaser, of equipment that proves to be defective, provided that the original purchaser:

1. Gives the manufacturer written notice within ten (10) days of discovery of such defect.
2. Immediately upon discovery of a claimed defect, discontinues all use of such equipment.
3. Returns such equipment freight prepaid to the manufacturer.

Manufacturer shall not be liable for any defects caused by the effects of normal wear and tear, erosion, corrosion, fire, or explosion; and shall not be liable for any special, indirect, or consequential damages incurred by the purchaser as a result of any claimed defect. As a further pre-condition to any manufacturer liability hereunder, purchaser shall return said purportedly defective equipment, freight prepaid, to the manufacturer. Midwest Cryogenics specifically makes no warranties or guarantees, expressed or implied, including but not limited to purpose or use, other than those specified herein. No warranties shall be implied under the uniform commercial code, other than the warranty of the title.

Accessories

You may find the following list of accessories helpful when it comes time to add on to your current system (not pictured in actual sizes).

E-Stop Control Panel

Features include flashing lights and audible alarms, a reset button, and a NEMA-12 enclosure.



Oxygen Monitor

This monitor has a digital display and two alarm contacts with a sensor life of ten or more years.

Phase Separators

For use at the end of transfer hoses, these separators reduce the amount of splashing that may occur when filling open dewars.



Pneumatic Valves

Valves are available in various sizes for use in conjunction with the E-Stop Control Panel and the Oxygen Monitor.

Transfer Hoses

Both vacuum jacketed and non-vacuum jacketed transfer hoses are available in various sizes and lengths.



Please visit our web site at www.midwestcryo.com to see available products.